

- Midlana Suspension Parts List
- Version 2
- Feb 11<sup>th</sup>, 2017
  
- In-bound suspension using ES2074R ball joints instead of spherical bearings on the front upper wishbones
  
- Changes:
  - Corrected high-misalignment rod ends for joints 27 and 27
  - Replaced clevises with 3/8" bore and 1/2" thread
  - Changed bungs for joints 14 and 14 with M16x1.5 that fit in 1" tube

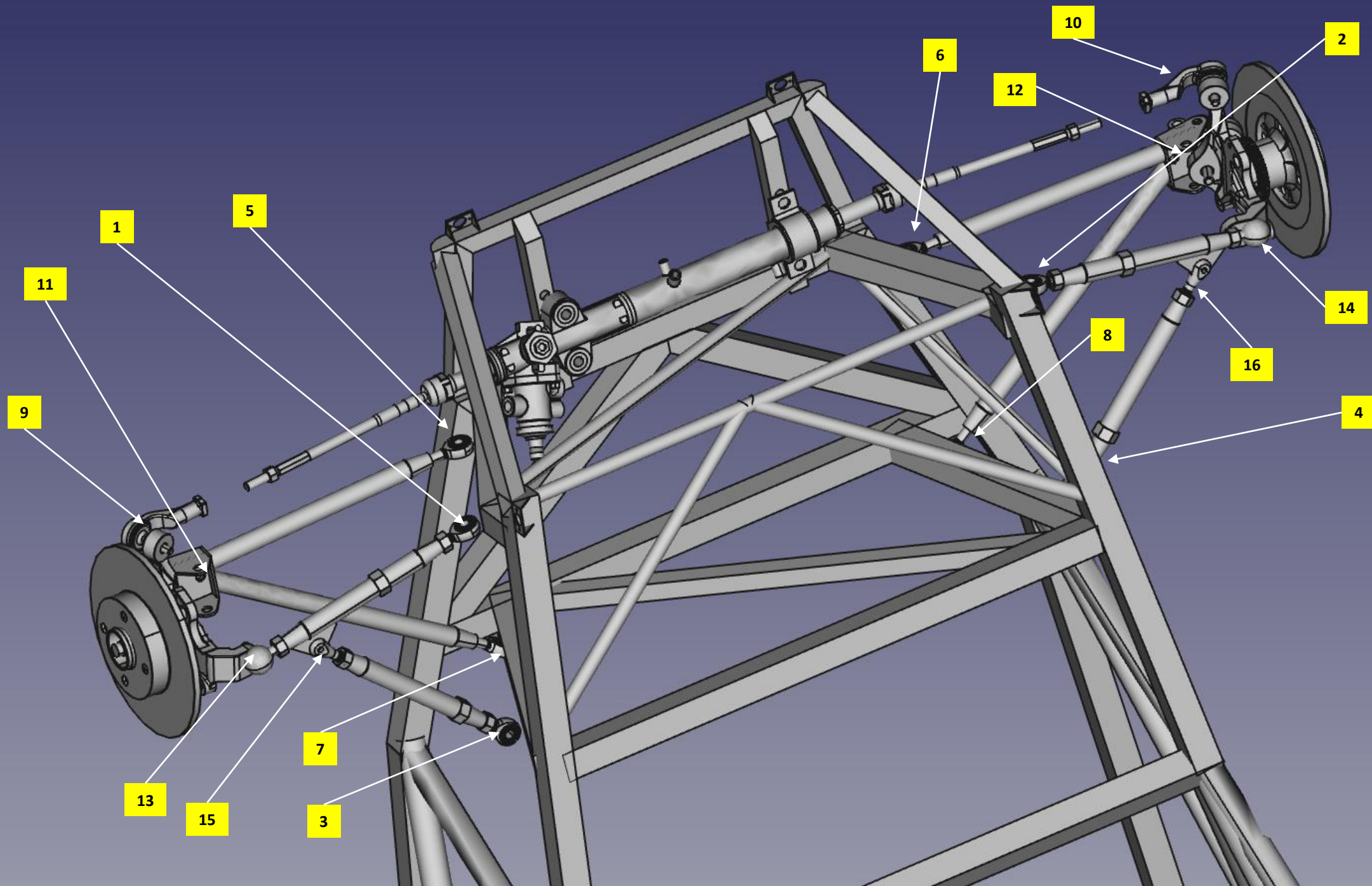

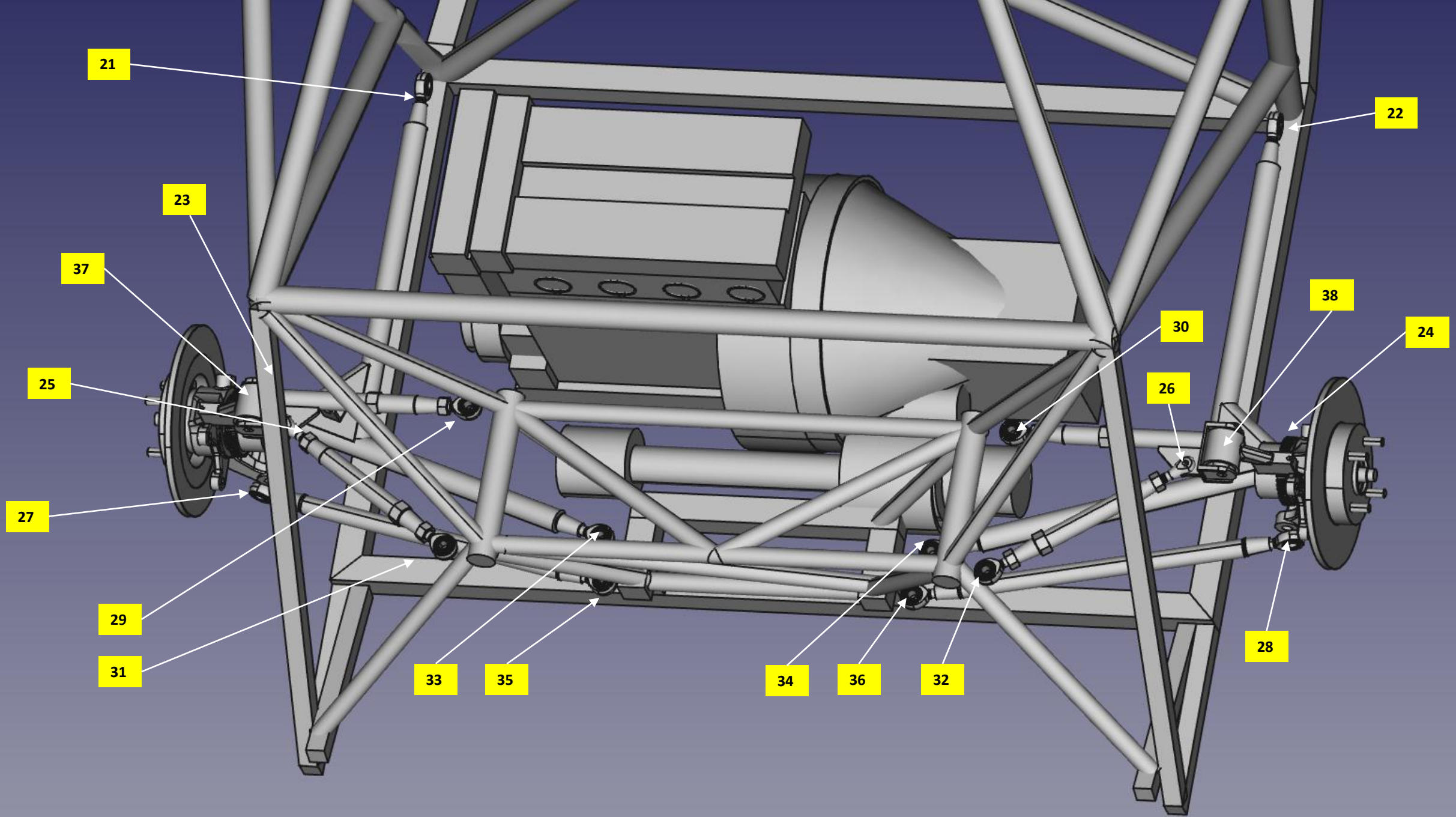



Rod Ends	Description	Ball Dia	Ball Bore	Thread Size	R/L Thread	Bung Required?	Supplier	Part No.	Local Currency Cost (Feb 2017) Ex. VAT
	1 Front Left Upper A-Arm, Forward, Inner Joint	5/8"	1/2"	1/2-20	L	Y	McGill	<a href="#">XML8-10</a>	GBP 8.09
	2 Front Right Upper A-Arm, Forward, Inner Joint	5/8"	1/2"	1/2-20	L	Y	McGill	<a href="#">XML8-10</a>	GBP 8.09
	3 Front Left Upper A-Arm, Rear, Inner Joint	5/8"	1/2"	1/2-20	L	Y	McGill	<a href="#">XML8-10</a>	GBP 8.09
	4 Front Right Upper A-Arm, Rear, Inner Joint	5/8"	1/2"	1/2-20	L	Y	McGill	<a href="#">XML8-10</a>	GBP 8.09
	5 Front Left Lower A-Arm, Forward, Inner Joint	5/8"	1/2"	1/2-20	L	Y	McGill	<a href="#">XML8-10</a>	GBP 8.09
	6 Front Right Lower A-Arm, Forward, Inner Joint	5/8"	1/2"	1/2-20	L	Y	McGill	<a href="#">XML8-10</a>	GBP 8.09
	7 Front Left Lower A-Arm, Rear, Inner Joint	5/8"	1/2"	1/2-20	L	Y	McGill	<a href="#">XML8-10</a>	GBP 8.09
	8 Front Right Lower A-Arm, Rear, Inner Joint	5/8"	1/2"	1/2-20	L	Y	McGill	<a href="#">XML8-10</a>	GBP 8.09
	21 Rear Left Lower Suspension Link, Forward Joint	5/8"	5/8"	5/8" UNF	R	Y	McGill	<a href="#">XMR10</a>	GBP 8.17
	22 Rear Right Lower Suspension Link, Forward Joint	5/8"	5/8"	5/8" UNF	R	Y	McGill	<a href="#">XMR10</a>	GBP 8.17
	27 Rear Left Toe Link, Outer Joint	5/8"	5/8"	1/2-20	R	Y	McGill	<a href="#">PCMR8-10T</a>	GBP 8.37
	28 Rear Right Toe Link, Outer Joint	5/8"	5/8"	1/2-20	R	Y	McGill	<a href="#">PCMR8-10T</a>	GBP 8.37
	29 Rear Left Upper A-Arm, Forward, Inner Joint	5/8"	1/2"	1/2-20	R	Y	McGill	<a href="#">XMR8-10</a>	GBP 8.09
	30 Rear Right Upper A-Arm, Forward, Inner Joint	5/8"	1/2"	1/2-20	R	Y	McGill	<a href="#">XMR8-10</a>	GBP 8.09
	31 Rear Left Upper A-Arm, Rear Inner Joint	5/8"	1/2"	1/2-20	L	Y	McGill	<a href="#">XML8-10</a>	GBP 8.09
	32 Rear Right Upper A-Arm, Rear Inner Joint	5/8"	1/2"	1/2-20	L	Y	McGill	<a href="#">XML8-10</a>	GBP 8.09
	33 Rear Left Lower Suspension Link, Rear, Inner Joint	5/8"	5/8"	5/8" UNF	R	Y	McGill	<a href="#">XMR10</a>	GBP 8.17
	34 Rear Right Lower Suspension Link, Rear, Inner Joint	5/8"	5/8"	5/8" UNF	R	Y	McGill	<a href="#">XMR10</a>	GBP 8.17
	35 Rear Left Toe Link, Inner Joint	5/8"	1/2"	1/2-20	L	Y	McGill	<a href="#">XML8-10</a>	GBP 8.09
	36 Rear Right Toe Link, Inner Joint	5/8"	1/2"	1/2-20	L	Y	McGill	<a href="#">XML8-10</a>	GBP 8.09
	41 Front Left Suspension Tie Rod Lower Joint	5/8"	1/2"	1/2-20	R	Y	McGill	<a href="#">XMR8-10</a>	GBP 8.09
	42 Front Right Suspension Tie Rod Lower Joint	5/8"	1/2"	1/2-20	R	Y	McGill	<a href="#">XMR8-10</a>	GBP 8.09
	43 Front Left Suspension Tie Rod Upper Joint	5/8"	1/2"	1/2-20	L	Y	McGill	<a href="#">XML8-10</a>	GBP 8.09
	44 Front Right Suspension Tie Rod Upper Joint	5/8"	1/2"	1/2-20	L	Y	McGill	<a href="#">XML8-10</a>	GBP 8.09
Clevis	Description		Bore	Thread Size					
	15 Front Left Upper A-Arm, Forward, Outer Joint		3/8"	1/2-20	R	Y	QA1	<a href="#">CR6-8</a>	USD 5.09
	16 Front Right Upper A-Arm, Forward, Outer Joint		3/8"	1/2-20	R	Y	QA1	<a href="#">CR6-8</a>	USD 5.09
	25 Rear Left Upper Suspension Link Outer Joint		3/8"	1/2-20	R	Y	QA1	<a href="#">CR6-8</a>	USD 5.09
	26 Rear Right Upper Suspension Link Outer Joint		3/8"	1/2-20	R	Y	QA1	<a href="#">CR6-8</a>	USD 5.09

Weldable Bungs	Description	Thread Size	R/L Thread			
1	Front Left Upper A-Arm, Forward, Inner Joint	1/2-20	L	McGill	<a href="#">BUNG8L</a>	GBP 3.06
2	Front Right Upper A-Arm, Forward, Inner Joint	1/2-20	L	McGill	<a href="#">BUNG8L</a>	GBP 3.06
3	Front Left Upper A-Arm, Rear, Inner Joint	1/2-20	L	McGill	<a href="#">BUNG8L</a>	GBP 3.06
4	Front Right Upper A-Arm, Rear, Inner Joint	1/2-20	L	McGill	<a href="#">BUNG8L</a>	GBP 3.06
5	Front Left Lower A-Arm, Forward, Inner Joint	1/2-20	L	McGill	<a href="#">BUNG8L</a>	GBP 3.06
6	Front Right Lower A-Arm, Forward, Inner Joint	1/2-20	L	McGill	<a href="#">BUNG8L</a>	GBP 3.06
7	Front Left Lower A-Arm, Rear, Inner Joint	1/2-20	L	McGill	<a href="#">BUNG8L</a>	GBP 3.06
8	Front Right Lower A-Arm, Rear, Inner Joint	1/2-20	L	McGill	<a href="#">BUNG8L</a>	GBP 3.06
13	Upper Left Ball Joint	M16-1.5	R	Rally Corsa Shop	<a href="#">kie16x1.5vhex</a>	EUR 12.90
14	Upper Right Ball Joint	M16-1.5	R	Rally Corsa Shop	<a href="#">kie16x1.5vhex</a>	EUR 12.90
15	Front Left Upper A-Arm, Forward, Outer Joint	5/8" UNF	R	McGill	<a href="#">BUNG10R</a>	GBP 3.19
16	Front Right Upper A-Arm, Forward, Outer Joint	5/8" UNF	R	McGill	<a href="#">BUNG10R</a>	GBP 3.19
21	Rear Left Lower Suspension Link, Forward Joint	5/8" UNF	R	McGill	<a href="#">BUNG10R</a>	GBP 3.19
22	Rear Right Lower Suspension Link, Forward Joint	5/8" UNF	R	McGill	<a href="#">BUNG10R</a>	GBP 3.19
25	Rear Left Upper Suspension Link Outer Joint	1/2-20	R	McGill	<a href="#">BUNG8R</a>	GBP 3.06
26	Rear Right Upper Suspension Link Outer Joint	1/2-20	R	McGill	<a href="#">BUNG8R</a>	GBP 3.06
27	Rear Left Toe Link, Outer Joint	1/2-20	R	McGill	<a href="#">BUNG8R</a>	GBP 3.06
28	Rear Right Toe Link, Outer Joint	1/2-20	R	McGill	<a href="#">BUNG8R</a>	GBP 3.06
29	Rear Left Upper A-Arm, Forward, Inner Joint	1/2-20	R	McGill	<a href="#">BUNG8R</a>	GBP 3.06
30	Rear Right Upper A-Arm, Forward, Inner Joint	1/2-20	R	McGill	<a href="#">BUNG8R</a>	GBP 3.06
31	Rear Left Upper A-Arm, Rear Inner Joint	1/2-20	L	McGill	<a href="#">BUNG8L</a>	GBP 3.06
32	Rear Right Upper A-Arm, Rear Inner Joint	1/2-20	L	McGill	<a href="#">BUNG8L</a>	GBP 3.06
33	Rear Left Lower Suspension Link, Rear, Inner Joint	5/8" UNF	R	McGill	<a href="#">BUNG10R</a>	GBP 3.19
34	Rear Right Lower Suspension Link, Rear, Inner Joint	5/8" UNF	R	McGill	<a href="#">BUNG10R</a>	GBP 3.19
35	Rear Left Toe Link, Inner Joint	1/2-20	L	McGill	<a href="#">BUNG8L</a>	GBP 3.06
36	Rear Right Toe Link, Inner Joint	1/2-20	L	McGill	<a href="#">BUNG8L</a>	GBP 3.06
41	Front Left Suspension Tie Rod Lower Joint	1/2-20	R	McGill	<a href="#">BUNG8R</a>	GBP 3.06
42	Front Right Suspension Tie Rod Lower Joint	1/2-20	R	McGill	<a href="#">BUNG8R</a>	GBP 3.06
43	Front Left Suspension Tie Rod Upper Joint	1/2-20	L	McGill	<a href="#">BUNG8L</a>	GBP 3.06
44	Front Right Suspension Tie Rod Upper Joint	1/2-20	L	McGill	<a href="#">BUNG8L</a>	GBP 3.06

Spherical Bearings	Description		Ball Bore	Ext Dia.					
	23 Rear Left Lower Suspension Link, Outer Joint		5/8"	1 1/8"			McGill	<a href="#">COM-10T</a>	GBP 4.74
	24 Rear Right Lower Suspension Link, Outer Joint		5/8"	1 1/8"			McGill	<a href="#">COM-10T</a>	GBP 4.74
	37 Rear Left Hub Upper Bearing		5/8"	1.5"			McGill	NA	
	38 Rear Right Hub Upper Bearing		5/8"	1.5"			McGill	NA	
	45 Left Rocker Arm Inner		1/2"	1"			McGill	<a href="#">COM-8T</a>	GBP 4.17
	46 Right Rocker Arm Inner		1/2"	1"			McGill	<a href="#">COM-8T</a>	GBP 4.17
	47 Left Rocker Arm Outer		1/2"	1"			McGill	<a href="#">COM-8T</a>	GBP 4.17
	48 Left Rocker Arm Inner		1/2"	1"			McGill	<a href="#">COM-8T</a>	GBP 4.17
Bearing Cups									
	23 Rear Left Lower Suspension Link, Outer Joint						McGill	<a href="#">COM10CUP + COM10CIRC</a>	GBP 5.35
	24 Rear Right Lower Suspension Link, Outer Joint						McGill	<a href="#">COM10CUP + COM10CIRC</a>	GBP 5.35
	45 Left Rocker Arm Inner						McGill	<a href="#">COM8CUP + COM8CIRC</a>	GBP 4.37
	46 Right Rocker Arm Inner						McGill	<a href="#">COM8CUP + COM8CIRC</a>	GBP 4.37
	47 Left Rocker Arm Outer						McGill	<a href="#">COM8CUP + COM8CIRC</a>	GBP 4.37
	48 Left Rocker Arm Inner						McGill	<a href="#">COM8CUP + COM8CIRC</a>	GBP 4.37
Lock Nuts									
	Description								
	10 x 1/2-20 Left Hand Thread			1/2-20	L		McGill	<a href="#">JNL8(QTY:10)</a>	GBP 7.10
	4 x 1/2-20 Left Hand Thread			1/2-20	L		McGill	<a href="#">JNL8(QTY:10)</a>	GBP 7.10
	6 x 1/2-20 Right Hand Thread			1/2-20	R		McGill	<a href="#">JNR8(QTY:10)</a>	GBP 3.92
	4 x 5/8" UNF Right Hand Thread			5/8" UNF	R		McGill	<a href="#">JNR10(QTY:10)</a>	GBP 5.55
Tie Rods									
	Description								
	9 Left Steering Tie Rod	1990 Mazda Miata Moog ES-3191 or equivalent			N		Moog	<a href="#">ES-3191</a>	USD 66.81
	10 Right Steering Tie Rod	1990 Mazda Miata Moog ES-3191 or equivalent			N		Moog	<a href="#">ES-3191</a>	USD 66.81
Ball Joints									
	Description								
	11 Lower Left Ball Joint	1990 Mazda Miata Moog K-9908 or equivalent			N		Moog	<a href="#">K9908</a>	USD 74.64
	12 Lower Right Ball Joint	1990 Mazda Miata Moog K-9908 or equivalent			N		Moog	<a href="#">K9908</a>	USD 74.64
	13 Upper Left Ball Joint	1990 Mazda Miata Moog ES-2074R or equivalent			Y		Moog	<a href="#">ES-2074R</a>	USD 18.78
	14 Upper Right Ball Joint	1990 Mazda Miata Moog ES-2074R or equivalent			Y		Moog	<a href="#">ES-2074R</a>	USD 18.78

Row Labels	Count of Description	Sum of Local Currency Cost (Feb 2017) Ex. VAT
McGill	70	359.51
BUNG10R	6	19.14
BUNG8L	14	42.84
BUNG8R	8	24.48
COM10CUP + COM10CIRC	2	10.7
COM-10T	2	9.48
COM8CUP + COM8CIRC	4	17.48
COM-8T	4	16.68
JNL8(QTY:10)	2	14.2
JNR10(QTY:10)	1	5.55
JNR8(QTY:10)	1	3.92
PCMR8-10T	2	16.74
XML8-10	14	113.26
XMR10	4	32.68
XMR8-10	4	32.36
Moog	6	320.46
ES-2074R	2	37.56
ES-3191	2	133.62
K9908	2	149.28
QA1	4	20.36
CR6-8	4	20.36
Rally Corsa Shop	2	25.8
kie16x1.5vhex	2	25.8
Grand Total	88	726.13

Row Labels	Count of Description						
1	2	13	2	26	2	37	1
Front Left Upper A-Arm, Forward, Inner Joint	2	Upper Left Ball Joint	2	Rear Right Upper Suspension Link Outer Joint	2	Rear Left Hub Upper Bearing	1
BUNG8L	1	ES-2074R	1	BUNG8R	1	NA	1
XML8-10	1	kie16x1.5vhex	1	CR6-8	1	38	1
2	2	14	2	27	2	Rear Right Hub Upper Bearing	1
Front Right Upper A-Arm, Forward, Inner Joint	2	Upper Right Ball Joint	2	Rear Left Toe Link, Outer Joint	2	NA	1
BUNG8L	1	ES-2074R	1	BUNG8R	1	41	2
XML8-10	1	kie16x1.5vhex	1	PCMR8-10T	1	Front Left Suspension Tie Rod Lower Joint	2
3	2	15	2	28	2	BUNG8R	1
Front Left Upper A-Arm, Rear, Inner Joint	2	Front Left Upper A-Arm, Forward, Outer Joint	2	Rear Right Toe Link, Outer Joint	2	XMR8-10	1
BUNG8L	1	BUNG10R	1	BUNG8R	1	42	2
XML8-10	1	CR6-8	1	PCMR8-10T	1	Front Right Suspension Tie Rod Lower Joint	2
4	2	16	2	29	2	BUNG8R	1
Front Right Upper A-Arm, Rear, Inner Joint	2	Front Right Upper A-Arm, Forward, Outer Joint	2	Rear Left Upper A-Arm, Forward, Inner Joint	2	XMR8-10	1
BUNG8L	1	BUNG10R	1	BUNG8R	1	43	2
XML8-10	1	CR6-8	1	XMR8-10	1	Front Left Suspension Tie Rod Upper Joint	2
5	2	21	2	30	2	BUNG8L	1
Front Left Lower A-Arm, Forward, Inner Joint	2	Rear Left Lower Suspension Link, Forward Joint	2	Rear Right Upper A-Arm, Forward, Inner Joint	2	XML8-10	1
BUNG8L	1	BUNG10R	1	BUNG8R	1	44	2
XML8-10	1	CR6-8	1	XMR8-10	1	Front Right Suspension Tie Rod Upper Joint	2
6	2	22	2	31	2	BUNG8L	1
Front Right Lower A-Arm, Forward, Inner Joint	2	Rear Right Lower Suspension Link, Forward Joint	2	Rear Left Upper A-Arm, Rear Inner Joint	2	XML8-10	1
BUNG8L	1	BUNG10R	1	BUNG8L	1	45	2
XML8-10	1	XMR10	1	XML8-10	1	Left Rocker Arm Inner	2
7	2	23	2	32	2	COM8CUP + COM8CIRC	1
Front Left Lower A-Arm, Rear, Inner Joint	2	Rear Left Lower Suspension Link, Outer Joint	2	Rear Right Upper A-Arm, Rear Inner Joint	2	COM-8T	1
BUNG8L	1	COM10CUP + COM10CIRC	1	BUNG8L	1	46	2
XML8-10	1	COM-10T	1	XML8-10	1	Right Rocker Arm Inner	2
8	2	24	2	33	2	COM8CUP + COM8CIRC	1
Front Right Lower A-Arm, Rear, Inner Joint	2	Rear Right Lower Suspension Link, Outer Joint	2	Rear Left Lower Suspension Link, Rear, Inner Joint	2	COM-8T	1
BUNG8L	1	COM10CUP + COM10CIRC	1	BUNG10R	1	47	2
XML8-10	1	COM-10T	1	XMR10	1	Left Rocker Arm Outer	2
9	1	25	2	34	2	COM8CUP + COM8CIRC	1
Left Steering Tie Rod	1	Rear Left Upper Suspension Link Outer Joint	2	Rear Right Lower Suspension Link, Rear, Inner Joint	2	COM-8T	1
ES-3191	1	BUNG8R	1	BUNG10R	1	48	2
10	1	CR6-8	1	XMR10	1	Left Rocker Arm Inner	2
Right Steering Tie Rod	1			35	2	COM8CUP + COM8CIRC	1
ES-3191	1			Rear Left Toe Link, Inner Joint	2	COM-8T	1
11	1			BUNG8L	1		
Lower Left Ball Joint	1			XML8-10	1		
K9908	1			36	2		
12	1			Rear Right Toe Link, Inner Joint	2		
Lower Right Ball Joint	1			BUNG8L	1		
K9908	1			XML8-10	1		